

**Taper Pipe**  
NPT/NPTF Medium Hook

Pipe Taps

Style: **PTT**

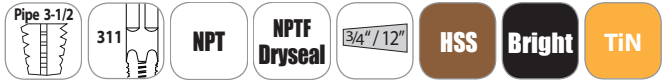

Machine Taps

Spiral Point Taps

Spiral Flute Taps

Thread Forming Taps

Pipe Taps

Dies

Technical Info

Sets

Index

**P**

**Note**  
Tapping speeds - see page 39-41.

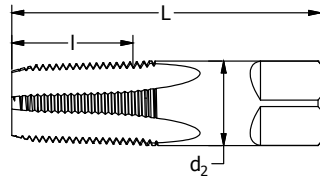

diameter & pitch	d <sub>2</sub> in	number of flutes	L in	I in	order number			
					NPT Bright	NPT TiN	NPTF Bright	NPTF TiN
1/16-27	.3125	4	2.1250	0.6875	385307	385328	385323	385329
*1/8-27	.3125	4	2.1250	0.7500	385331	385357	385356	385359
1/8-27	.4375	4	2.1250	0.7500	385364	385385	385380	385386
1/4-18	.5625	4	2.4375	1.0625	385398	385409	385413	385410
3/8-18	.7000	4	2.5625	1.0625	385422	385443	385448	385444
1/2-14	.6875	4	3.1250	1.3750	385455	385458	385471	385477
3/4-14	.9063	5	3.2500	1.3750	385489	385500	385505	385501
1 - 11-1/2	1.1250	5	3.7500	1.7500	385513	385534	385539	385536
1-1/4 - 11-1/2	1.3125	5	4.0000	1.7500	385547	385680	385562	385685
1-1/2 - 11-1/2	1.5000	7	4.2500	1.7500	385570	385681	—	—
2 - 11-1/2	1.8750	7	4.5000	1.7500	385604	385682	—	—

\*small shank

**Taper Pipe**  
NPT/NPTF Medium Hook

SET

Style: **PTT**

	order number
NPT Pipe Tap: 1/8 - 1" NPT	353768

**Tech Tip**

**Tap Drill Recommendations - NPT, NPTF, NPSM, NPSC, NPSF Sizes**

**Color Code:**  
Wire Gage - Purple  
Fractional - Red,  
Letter - Blue,  
and  
Metric Sizes - Green

Nominal Tap Size & Pitch	NPT & NPTF		NPSM	NPSC	NPSF
	w/o reamer	w/ reamer			
1/16 - 27	C (.242)	A (.234)	—	1/4	D (.246)
1/8 - 27	Q (.332)	21/64	T (.358)	Q	R (.339)
1/4 - 18	7/16	27/64	15/32	7/16	7/16
3/8 - 18	9/16	9/16	.603*	37/64	37/64
1/2 - 14	45/64	11/16	19.0mm	23/32	.705*
3/4 - 14	29/32	57/64	61/64	59/64	59/64
1 - 11 <sup>1</sup> / <sub>2</sub>	1-9/64	1-1/8	1-13/64	1-5/32	1-5/32
1 <sup>1</sup> / <sub>4</sub> - 11 <sup>1</sup> / <sub>2</sub>	1-31/64	1-15/32	1.546*	1-1/2	—
1 <sup>1</sup> / <sub>2</sub> - 11 <sup>1</sup> / <sub>2</sub>	1-23/32	1-45/64	1-25/32	1-47/64	—
2 - 11 <sup>1</sup> / <sub>2</sub>	2-3/16	2-11/64	2-1/4	2-1/4	—

\*special



Pipe Taps

Style: **PTTI**

Taper Pipe

NPT/NPTF Medium Hook Interrupted

**P**

**Note**

Tapping speeds - see page 39-41.



- Machine Taps
- Spiral Point Taps
- Spiral Flute Taps
- Thread Forming Taps
- Pipe Taps**
- Dies
- Technical Info
- Sets
- Index

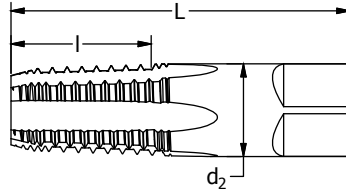

diameter & pitch	d <sub>2</sub> in	number of flutes	L in	I in	order number		
					NPT Bright	NPTF Bright	NPTF TiN
*1/8-27	.3125	4	2.125	.750	—	385752	—
1/8-27	.4375	4	2.125	.750	385737	385729	385755
1/4-18	.5625	4	2.438	1.063	385760	385786	385789
3/8-18	.7000	4	2.563	1.063	385794	385810	385813
1/2-14	.6875	4	3.125	1.375	385828	385844	385847
3/4-14	.9063	5	3.250	1.375	385851	385877	385870
1-11-1/2	1.1250	5	3.750	1.750	385885	—	—

\* small shank

## Tech Tip Pipe Taps

General purpose pipe taps are appropriate for threading a wide variety of materials, both ferrous and non-ferrous.

Ground thread pipe taps are standard in American Standard Pipe Form (NPT) and American Standard Dryseal Pipe Form (NPFT). NPT threads require the use of a sealer, like Teflon® tape or pipe compound. Dryseal taps are used to tap fittings which will give a pressure-tight joint without the use of a sealer.

The nominal size of a pipe tap is that of the pipe fitting to be tapped, not the actual size of the tap. The thread tapers 3/4" per foot.

All pipe taps are furnished with 2 1/2 to 3-1/2 thread chamfer.

Short projection pipe taps are made with a projection shorter than standard for taper pipe tapping where the depth of tapping is limited. Special short projection pipe taps and left hand pipe taps are available as specials.

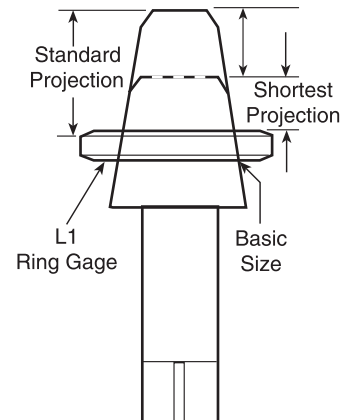

**NPS/NPSM/NPSC/NPSF**  
Medium Hook Straight Pipe

Pipe Taps



Style: **PTS**

**P**

Mod 3-5   311   NPS   NPSF Dryseal   NPSM   NPSC   3/4" / 12"   HSS   Bright

**Note**  
Tapping speeds - see page 39-41.

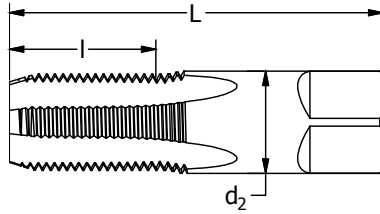

order number

diameter & pitch	d <sub>2</sub> in	number of flutes	L in	I in	order number	
					NPS/NPSM NPSC Bright	NPSF Bright
*1/8-27	.3125	4	2.125	.750	—	387212
1/8-27	.4375	4	2.125	.750	387113	387220
1/4-18	.5625	4	2.438	1.063	387121	387238
3/8-18	.7000	4	2.563	1.063	387139	387246
1/2-14	.6875	4	3.125	1.375	387147	387253

\* small shank

- Machine Taps
- Spiral Point Taps
- Spiral Flute Taps
- Thread Forming Taps
- Pipe Taps
- Dies
- Technical Info
- Sets
- Index



Pipe Taps  
Style: **ELPTT**

CNC Extra Length Med. Hook  
with Machine Tap Shanks

**P**

**Note**

Tapping speeds -  
see page 39-41.



**NPT**

**NPTF  
Dryseal**

3/4" / 12"

**HSS**

**Bright**

**TiN**

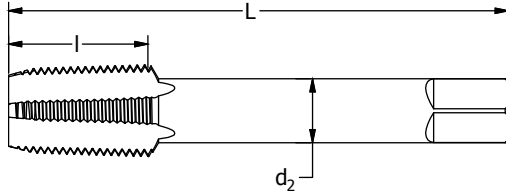

diameter & pitch	d <sub>2</sub> in	number of flutes	L in	I in	order number		
					NPT Bright	NPTF Bright	NPTF TiN
1/8-27	0.318	4	3.000	.750	384524	386008	386129
1/4-18	0.480	4	3.500	1.063	384525	386024	386152
3/8-18	0.480	4	3.750	1.063	384526	386040	386186
1/2-14	0.480	4	4.375	1.375	384527	—	—
3/4-14	0.800	5	4.625	1.375	384528	—	—
1-11-1/2	0.800	5	5.250	1.750	384529	—	—

- Machine Taps
- Spiral Point Taps
- Spiral Flute Taps
- Thread Forming Taps
- Pipe Taps**
- Dies
- Technical Info
- Sets
- Index